

REV.	DESCRIPTION	ENGR	DATE
1	First Release	JWL	5/24/2018

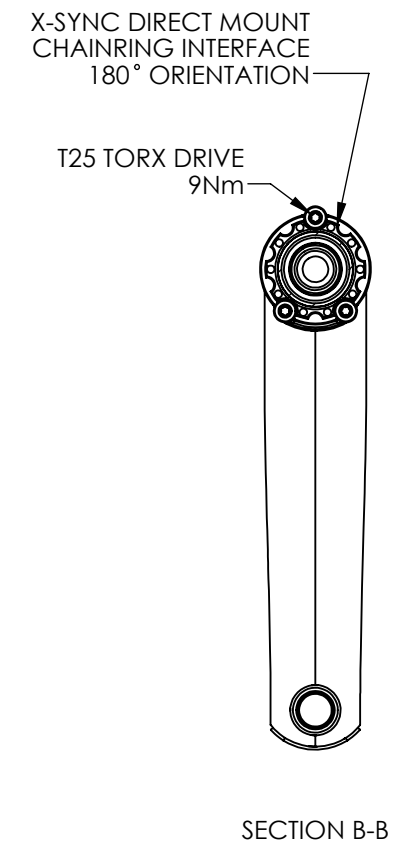
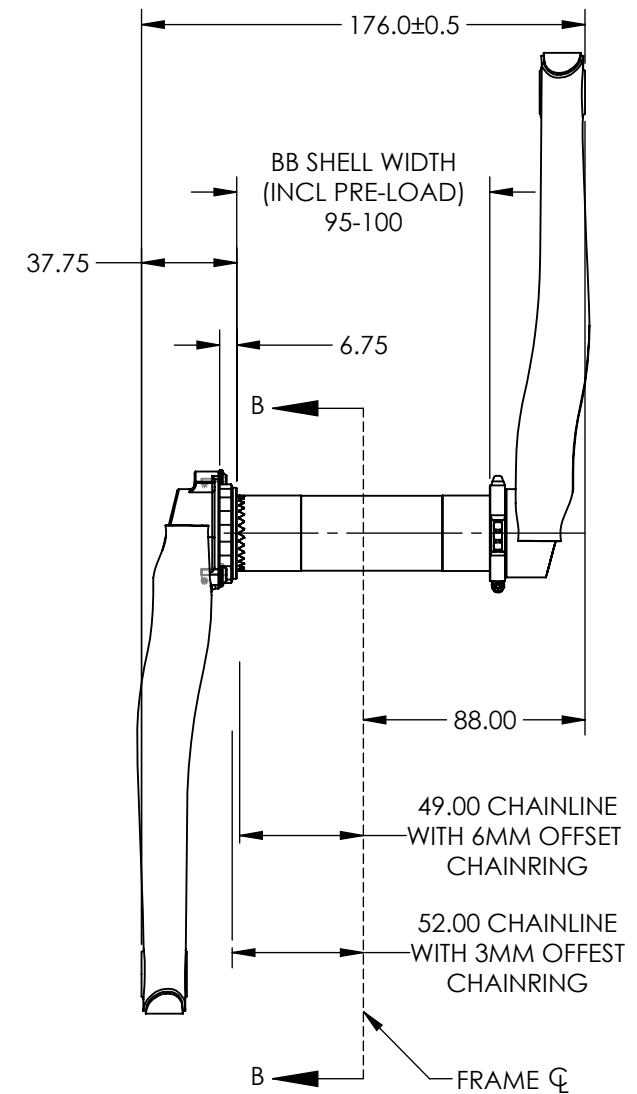
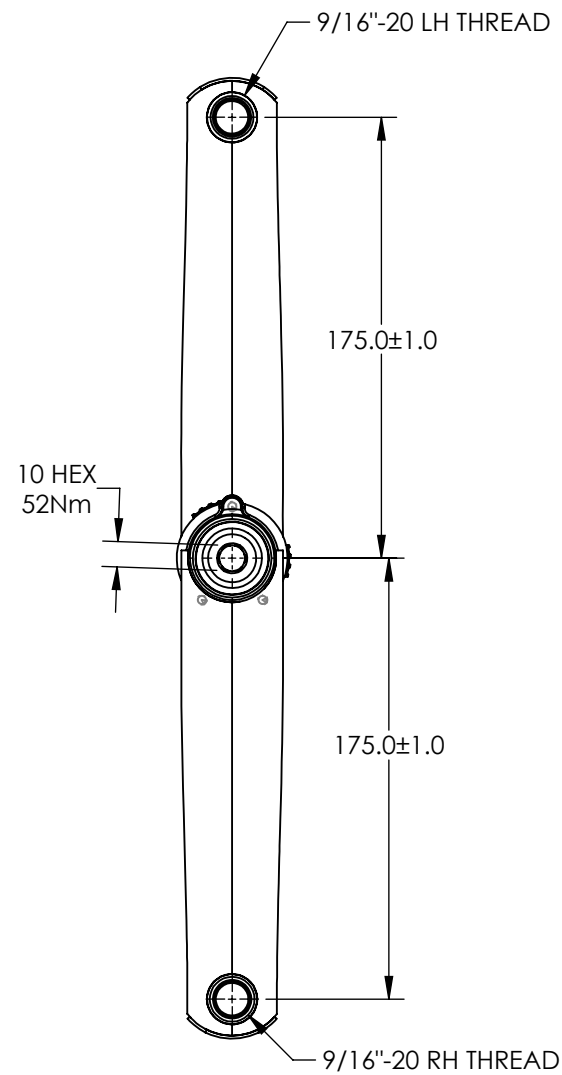
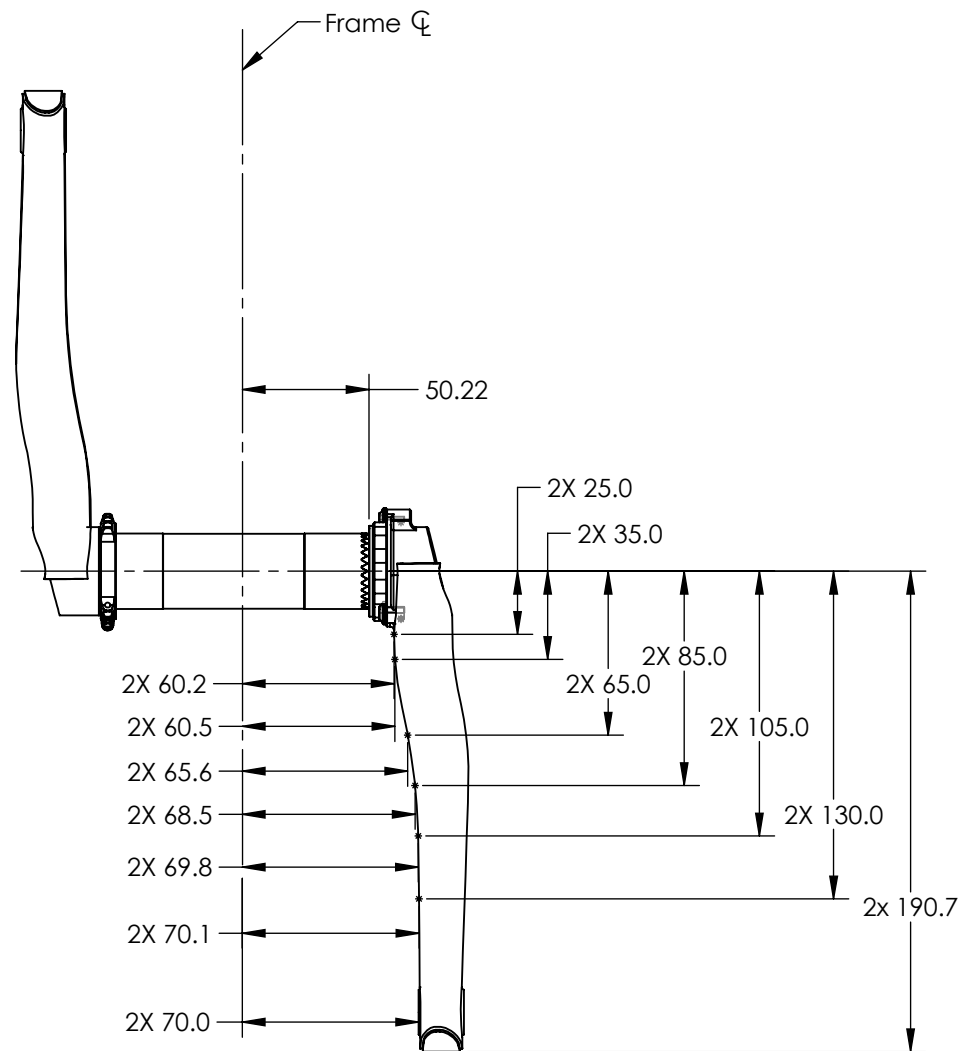

NOTES: UNLESS OTHERWISE SPECIFIED

1. CANE CREEK RESERVES THE RIGHT TO CHANGE SPECIFICATIONS WITHOUT PRIOR NOTICE. DRAWING NOT TO SCALE
2. MINIMUM RECOMMENDED FRAME CLEARANCE: 2.5MM. CUSTOMER IS RESPONSIBLE FOR ENSURING CLEARANCE
3. 30MM BOTTOM BRACKETS ONLY
4. BSA73 SHELL REQUIRES 2.5mm SPACER BEHIND DRIVE SIDE BEARING CUP
5. PF30 & BB30 SHELLS REQUIRE USE OF EXTERNAL CUP BOTTOM BRACKET
6. COMPATIBLE WITH X-SYNC CHAINRINGS ONLY

mm Dimensions Tolerances: .X ± 0.3 .XX ± 0.10 .XXX ± 0.05 Angular: ± 0.5 Concentricity: 0.10 Third Angle Projection	This drawing and all information therein is the property of Cane Creek Cycling Components and is confidential and must not be made public or copied. It is loaned subject to return upon demand and is not to be used in any way that is detrimental to our interests.	CANE CREEK	
Material: Ti/Al Weight: Finish: Scotch brite	Color: NA	TITLE: eeWings 175mm Complete Assembly	
SIZE B	Part No. BAI0022	REV. 01	SCALE: 1:3 SHEET 1 OF 1